

Assembly Instructions

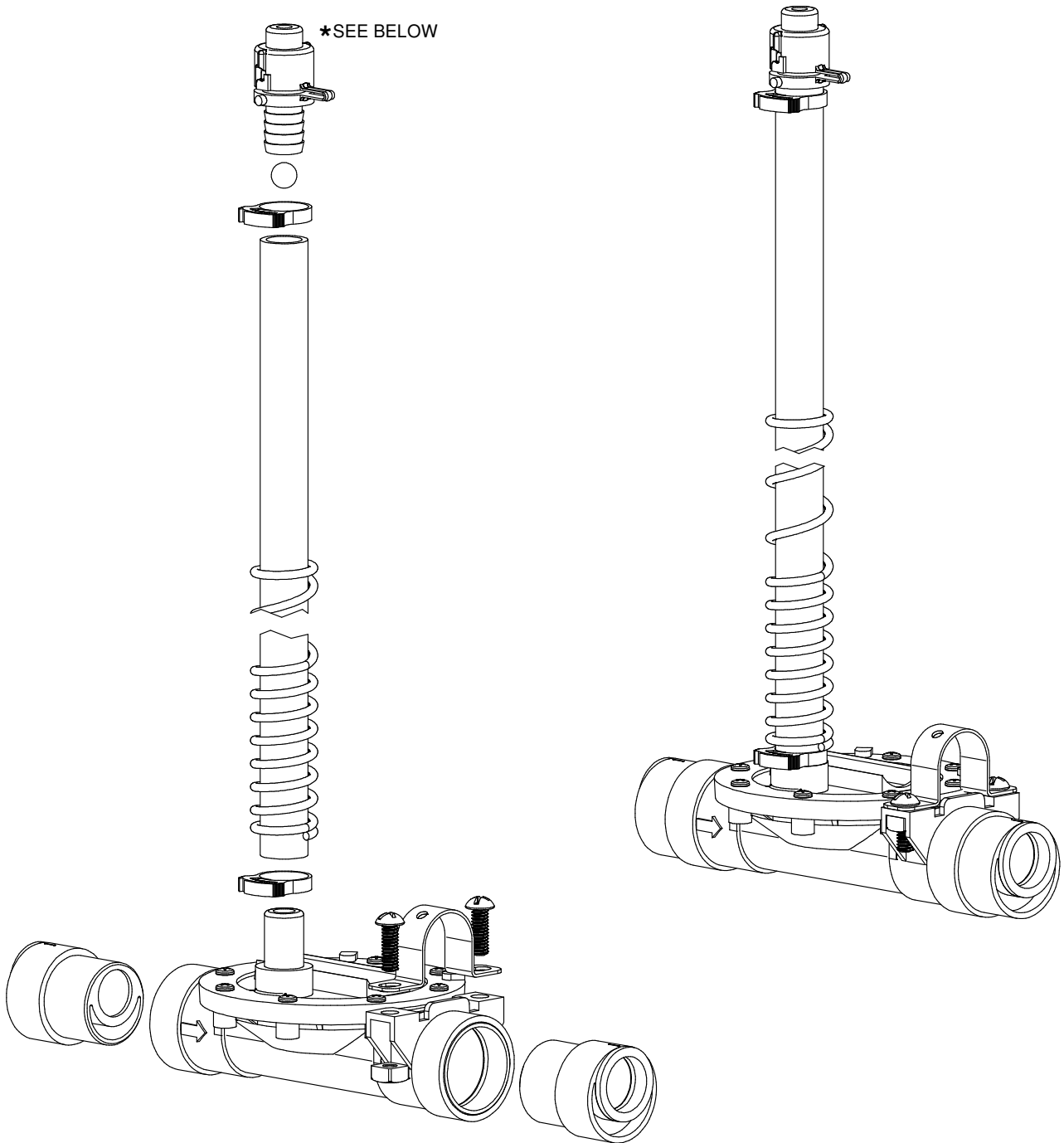

**CAUTION**

- DO NOT ALLOW THIS ITEM TO COME INTO CONTACT WITH PETROLEUM, PHENOL OR ALDEHYDE BASED PRODUCTS OR ANY OTHER CORROSIVE PRODUCT IN GENERAL.
- \*IF PRESSURE DURING FLUSHING IS BELOW 5 PSI/0.35 BAR SEE GL1089

# 1920B-4 COMPONENTS

PART NR.	QTY	DESCRIPTION
122-24	1	RISER TUBE: 24" / 60 CM
1369	2	ADAPTER: BIG ACE SPIGOT X ACE SLIP
147	1	BALL: RISER TUBE
159	2	FASTENER: SCREW PAN HD PHILLIPS 1/4" - 20 X 3/4" LG
160	2	FASTENER: NUT CROWN SQ 1/4" - 20 X 7/16" WD X 1/4" H
1895	1	SPRING: RISER TUBE
114	2	DRINKER PART: BALL - 5/16" EPDM & SS DRINKERS
1783	2	DRINKER PART: BALL - 7/16" BIG Z
1809	1	SLOPE NEUTRALIZER PART: TOP
1987	1	SLOPE NEUTRALIZER PART: BODY
2360	1	O-RING: 3.161" ID X 3.44" OD X 0.139" CS
2412	2	SLOPE NEUTRALIZER PART: BALL RETAINER
83	8	FASTENER: SCREW PAN HD PHILLIPS #7 - 18 X 1/2" LG - PLASTITE THREAD
2005	1	RISER TUBE CAP
2643	1	CLAMP: FLOOR NEUTRALIZER MOUNT
511	2	CLAMP: SNAP 0.746" - 0.848" DIA. - BLACK

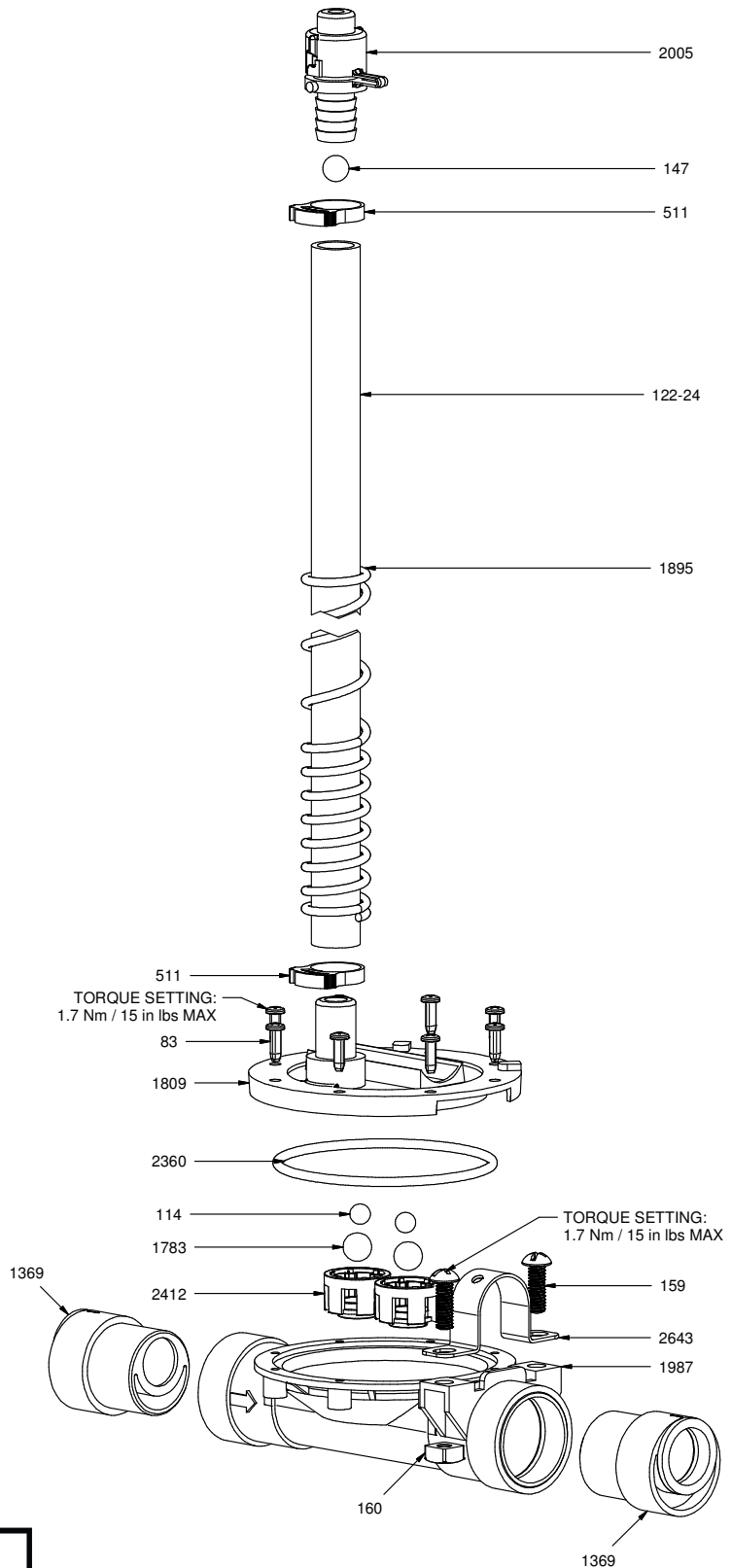
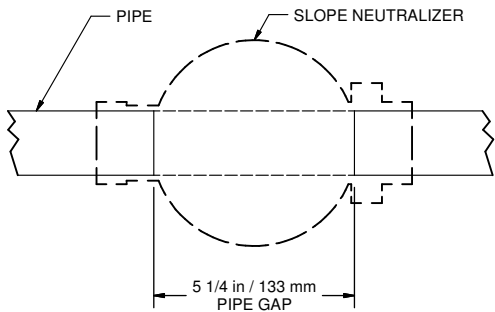
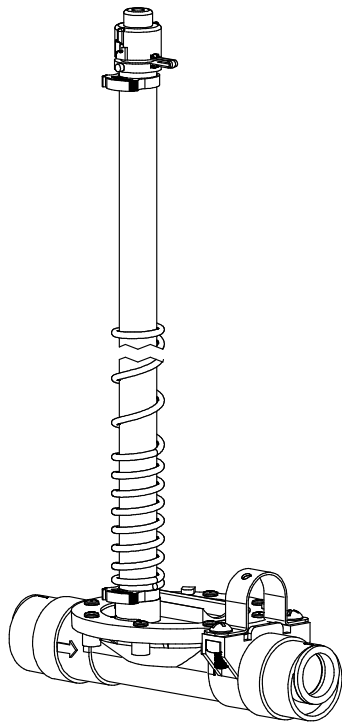

Ziggy Systems Inc.  
 101 Industrial Parkway East  
 Middlebury Indiana 46540-8549  
 USA  
 Tel: + 1 574.825.5849  
 Fax: + 1 574.825.7674  
 Web: www.ziggy.com