

Assembly Instructions

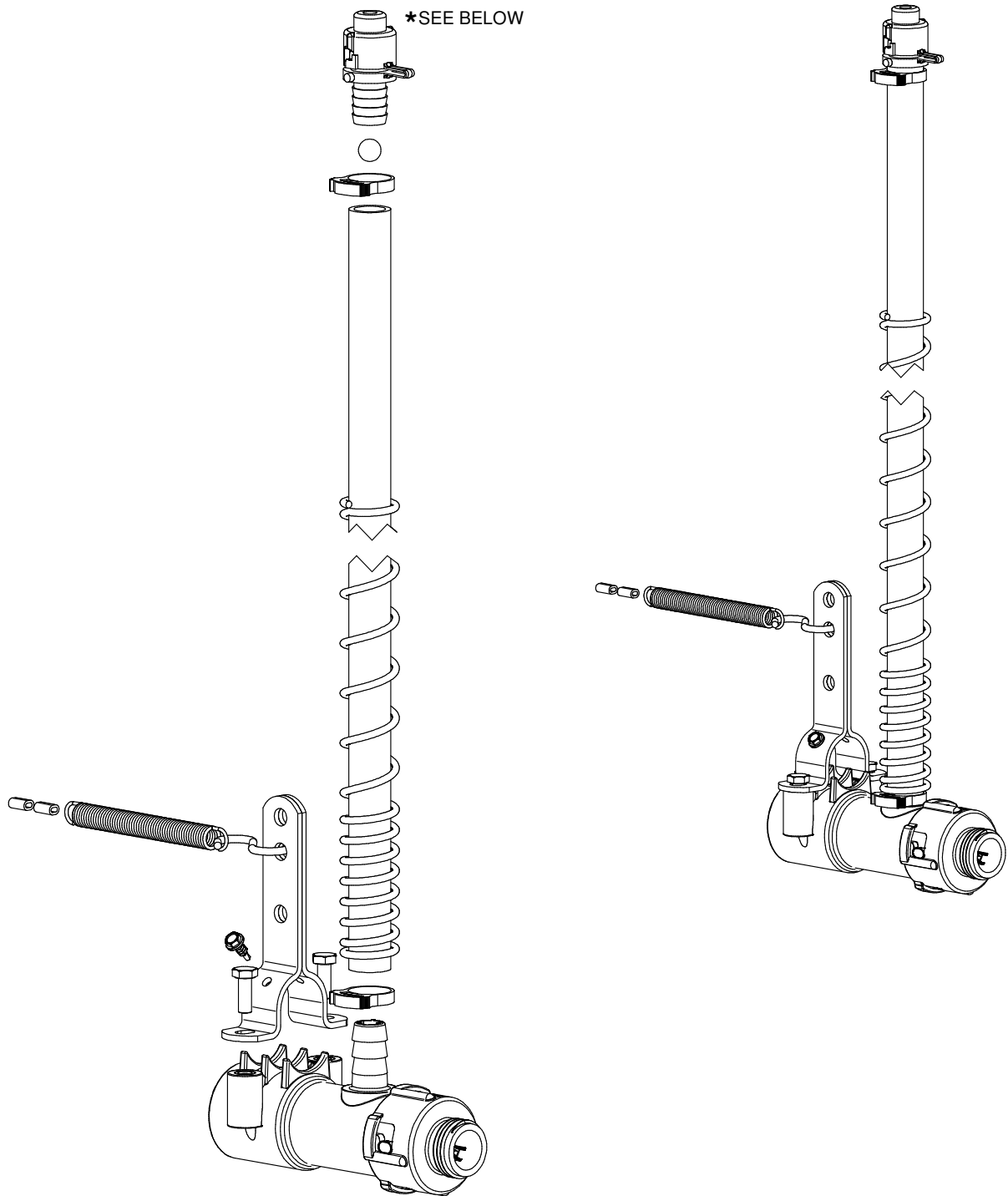

CAUTION

- DO NOT ALLOW THIS ITEM TO COME INTO CONTACT WITH PETROLEUM, PHENOL OR ALDEHYDE BASED PRODUCTS OR ANY OTHER CORROSIVE PRODUCT IN GENERAL.
- *IF PRESSURE DURING FLUSHING IS BELOW 5 PSI/0.35 BAR SEE GL1089

2930 COMPONENTS

PART NR.	QTY	DESCRIPTION
122-24	1	RISER TUBE: 24" / 60 CM
147	1	BALL: RISER TUBE
1895	1	SPRING: RISER TUBE
2005	1	RISER TUBE CAP
206	1	SPRING: ANTI-ROOST
207	2	CLIP: ANTI-ROOST CABLE
2089	2	FASTENER: BOLT HEX HD M6 X 1 X 16 LG
2537	1	FASTENER: SCREW HEX WHD SELF TAPPING #8-18 X 1/2" LG
1171	1	END ASSEMBLY PART: BALL
2617	1	FLOOR END ASSEMBLY PART: BODY
2618	1	FLOOR END ASSEMBLY PART: O-RING RETAINER
2619	1	FLOOR END ASSEMBLY PART: END CAP - MHT
2621	1	O-RING: 209 - 0.671" ID X 15/16" OD X 0.139" CS
2622	1	FLOOR END ASSEMBLY PART: SPRING
2623	1	FLOOR END ASSEMBLY PART: END CAP RUBBER WASHER
2765	1	S-HOOK: ANTI-ROOST CABLE ANCHOR
511	2	CLAMP: SNAP 0.746" - 0.848" DIA. - BLACK
898	1	CLAMP: SUPPORT PIPE TO FLOOR REGULATOR

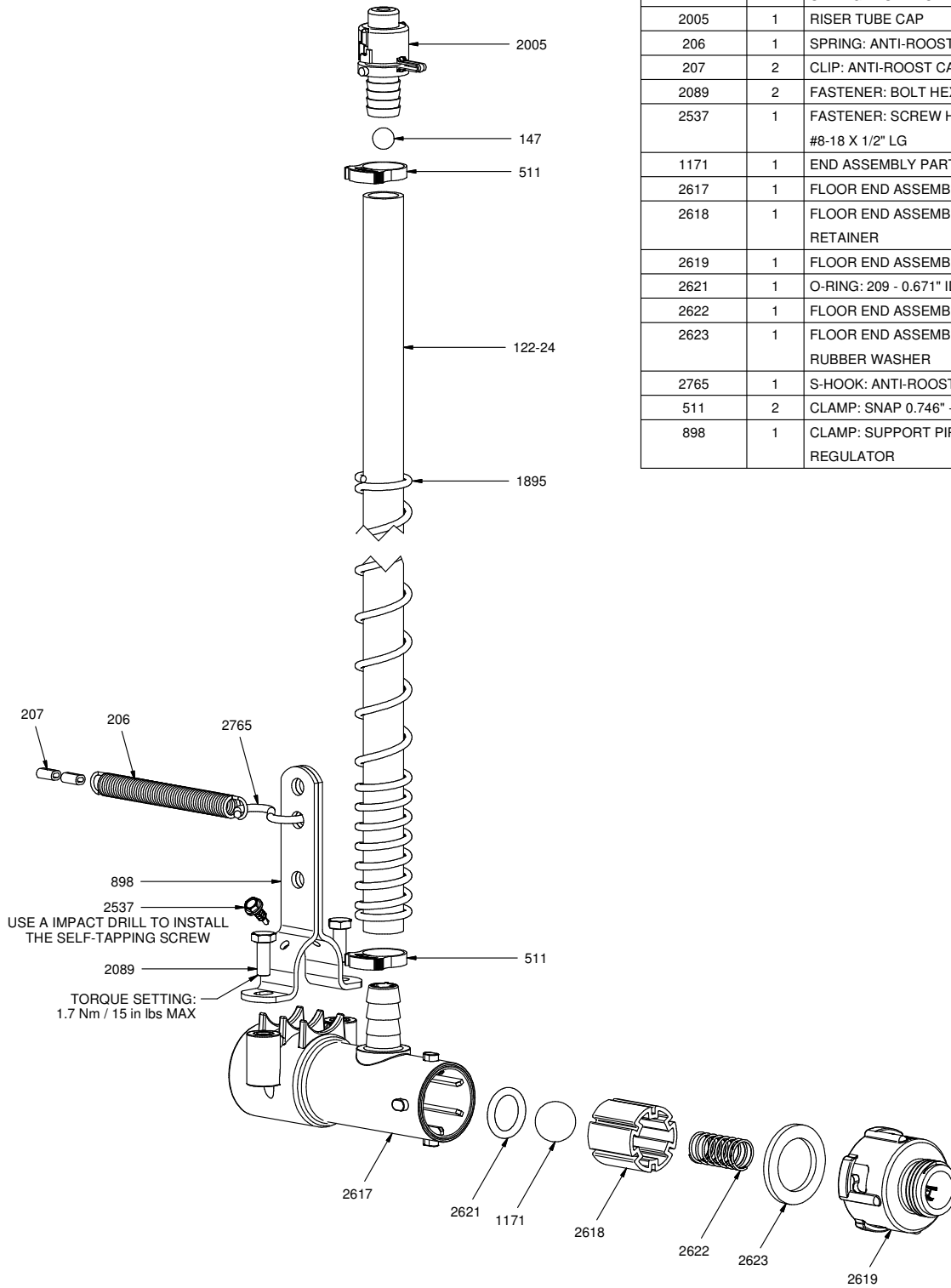

Ziggy Systems Inc.
 101 Industrial Parkway East
 Middlebury Indiana 46540-8549
 USA
 Tel: + 1 574.825.5849
 Fax: + 1 574.825.7674
 Web: www.ziggy.com