

Assembly Instructions

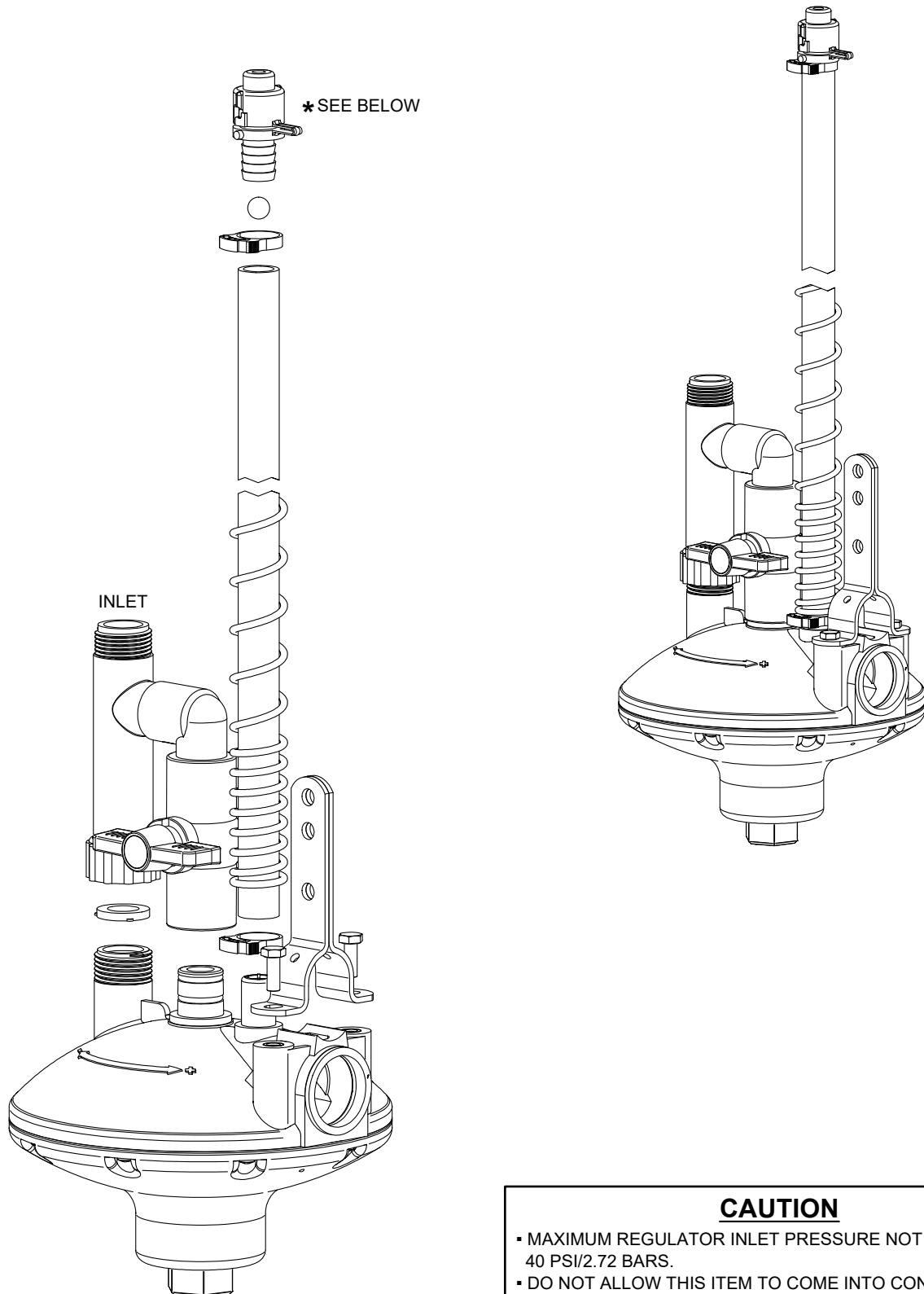

CAUTION

- MAXIMUM REGULATOR INLET PRESSURE NOT TO EXCEED 40 PSI/2.72 BARS.
- DO NOT ALLOW THIS ITEM TO COME INTO CONTACT WITH PETROLEUM, PHENOL OR ALDEHYDE BASED PRODUCTS OR ANY OTHER CORROSIVE PRODUCT IN GENERAL.
- IF PRESSURE DURING FLUSHING IS BELOW 5 PSI/0.35 BAR SEE GL1089

2949 COMPONENTS

PART NR.	QTY	DESCRIPTION
122-24	1	RISER TUBE: 24" / 60 CM
1373	1	REGULATOR PART: FLUSH UNIT 3/4" MNPT INLET RED
147	1	BALL: RISER TUBE
1895	1	SPRING: RISER TUBE
2005	1	RISER TUBE CAP
2089	2	FASTENER: BOLT HEX HD M6 X 1 X 16 LG
1016	1	REGULATOR PART: ADJUSTMENT KNOB ASSEMBLY - AT & INLINE
1357	1	REGULATOR PART: INLET/OUTLET HOUSING - FLOOR
187	1	REGULATOR PART: ADJUSTMENT HOUSING - STANDARD & INLINE
157	1	WASHER: METAL - 5/16" ID X 3/4" OD X 0.044" TH
181	1	REGULATOR PART: DIAPHRAGM - STANDARD
417	1	O-RING: 6.40MM ID X 10.21MM OD X 1.90MM CS
89	1	FASTENER: NUT HEX 5/16" - 18 X 1/2" WD X 17/64" H
91	1	REGULATOR PART: SWIVEL COUPLING - STANDARD
92	1	REGULATOR PART: SHOULDER BOLT - STANDARD
97	1	REGULATOR PART: DIAPHRAGM BACKING PLATE - STANDARD
506	1	REGULATOR PART: SPRING 0.05 - 1 PSI
83	11	FASTENER: SCREW PAN HD PHILIPS #7-18 X 1/2" LG
87	2	REGULATOR PART: RETAINER BLOCK - STANDARD
888	1	REGULATOR PART: OPENING ARM W/ SEAT
3949	1	REGULATOR PART: ARF RING
511	2	CLAMP: SNAP 0.746" - 0.848" DIA. - BLACK
898	1	CLAMP: SUPPORT PIPE TO FLOOR REGULATOR

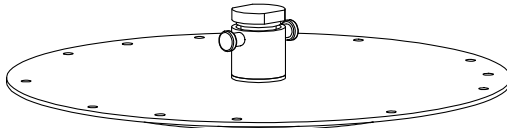
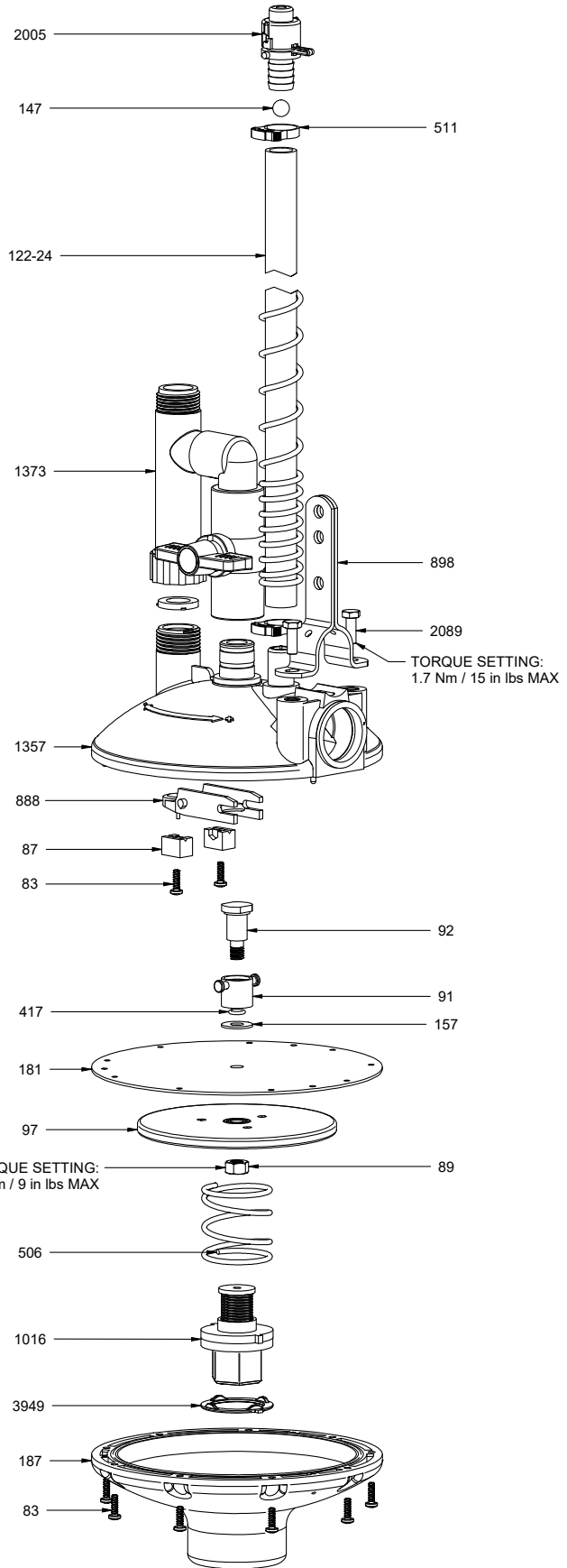

301 DIAPHRAGM ASSEMBLY - STANDARD

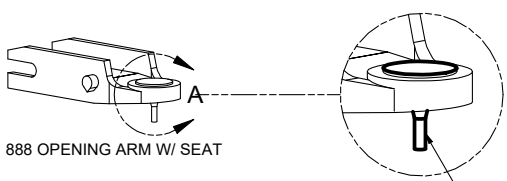

888 OPENING ARM W/ SEAT

88-V CAN BE PURCHASED SEPARATELY

Ziggity Systems Inc.
 101 Industrial Parkway East
 Middlebury Indiana 46540-8549
 USA
 Tel: + 1 574.825.5849
 Fax: + 1 574.825.7674
 Web: www.ziggity.com